

User Manual XC Tracer Maxx II



Quick Start Guide

Attach the vario on the cockpit or on your thigh. Press the red button and wait until beep-beep, then release the button. At first only the logo appears, after a few seconds the preset screen appears. While the vario is searching for GPS satellites, the word GPS will flash in the upper right corner. As soon as a GPS fix has been acquired, the battery symbol is displayed and you can start. You can change the screen by a short push on the button. You can change the volume level by double-clicking on the button. After landing, switch the vario off by pressing the button until you hear beep-beep, then release the button.

If you want to change the settings: press the button twice in quick succession and hold it down for a second on the second click. To get to the desired setting press the button once briefly; with a long press select/change the setting. The vario is preset to beep only when flying. But you can set this as you wish.

If you want to download the tracks or change the configuration file then connect XC Tracer Maxx II to your computer with the included USB-C cable. Now switch on the vario and the SD card of XC Tracer Maxx II will appear on the computer as a USB hard drive. Now you can download tracks, change settings in the config file, or copy new firmware updates to the SD card. The new firmware is installed as soon as you switch off the vario.

Important: Always eject the SD card before disconnecting from the computer.

WARNING: Charge the battery with the USB cable on the PC or on a 5V charger. Only a 5V connection / charger may be used, do not use Fast Charge / Quick Charge / Super Charge / Turbo Power or whatever. If a voltage higher than 5V is used while charging, the electronics will be destroyed. Never use a cheap charger; this can damage your XC Tracer Maxx II.

We accept no responsibility for damage which occurs when not using the correct voltage for charging!

Introduction

XC Tracer Maxx II is a high-precision GPS variometer with a perfectly readable LCD and integrated collision warning using FLARM. XC Tracer Maxx II transmits its position once per second and also the estimated flight path for the next 20 seconds. Other FLARM devices in the vicinity can then draw conclusions about a possible risk of collision. In case of a possible collision the corresponding FLARM device warns the pilot of the other aircraft. XC Tracer Maxx II itself does not warn you of possible collisions with other aircraft.

Many pilots use XC Tracer flight instruments for long XC flights and for competitions. But also for pilots with little flying experience an XC Tracer Variometer is the perfect choice. The lag-free indication of lift / sink rate makes it much easier to find and core thermals than when using a conventional variometer. All essential flight information is displayed on the LCD.

XC Tracer Maxx II is also an IGC logger – the IGC files are approved by the FAI for paragliding competitions. XC Tracer Maxx II has a built-in lithium-polymer battery, fully charged the battery is good for at least 60 hours of continuous operation. The battery is charged via the supplied USB-C cable. The device also has a Bluetooth module. Using Bluetooth Low Energy 4.2, data such as airspeed, altitude, climb, course etc. can be transferred to a mobile phone, tablet or e-reader. Please check xctracer.com to see which apps need to be configured with which BLE strings.

Mounting

XC Tracer Maxx II uses data from a 9-DOF IMU (9 Degrees Of Freedom Inertial Measurement Unit), from the GPS and from a pressure sensor, to compute the real-time climb rate and altitude, avoiding the undesired time lag that conventional variometers suffer from (due to data filtering). For this reason mount your XC Tracer Maxx II in such a way that it moves as little as possible in relation to the harness during flight.

It is therefore important that the XC Tracer Maxx II is firmly attached to the cockpit or thigh with the velcro provided. Mounting on the riser is not ideal.

Important – leave 4-5cm free space around your vario; otherwise the performance of the FLARM / FANET beacon may be compromised.

Switch On/Switch Off

The XC Tracer Maxx II is switched on by pressing the red button until a "beep-beep" is heard. Then release the button and the XC Tracer Maxx II will start up. After switching on, the battery charge level is indicated acoustically. At first only the logo appears, after a few seconds the preset screen appears. As long as the vario is searching for GPS satellites, the word GPS flashes in the upper right corner. As soon as it has a GPS fix, this lettering disappears and the battery symbol is displayed. Now you can start. You can change the screen by a short push on the button. You can change the volume by double clicking on it. After landing, switch off the vario by pressing the button until you hear a beep-beep and the vario is switched off.

Battery Indicator

After switching the device on the battery charge status is indicated with a sequence of short beeps:

- 5x Beep means that the battery is charged 95% or more.
- 4x Beep means that the battery is charged 75% or more.
- 3x Beep means that the battery is charged 55% or more.
- 2x Beep means that the battery is charged 35% or more.
- 1x Beep means that the battery is charged 15% or more.

When the battery is less than 15% charged you will hear a constant beep for one second after switching the device on. The battery charge level is also displayed on the LCD.

Adjusting The Volume

XC Tracer Maxx II has 4 volume settings: Mute, very gentle, gentle, medium and loud. You can change the volume level by double pressing the red button (like a double click on the mouse of your computer), always from mute – very gentle – gentle - medium – loud – mute – very gentle etc.

Power management

A fully charged battery from the XC Tracer Maxx II is sufficient to run the vario for up to 70 hours, including logging of IGC and KML files, sending and receiving of FLARM Beacons, data transfer over BLE etc. After successful landing the vario should be switched off to save power. If you've had a bad landing or accident and potentially need medical assistance, then leave your vario on in order to support a possible search and rescue by the emergency services.

The battery can be charged via the USB port. To do this, use the USB-C charging cable provided and charge the XC Tracer Maxx II overnight. Fully charging an empty battery takes about 5 hours.

WARNING: Charge the battery with the USB cable on the PC or on a 5V charger. Only a 5V connection / charger may be used, do not use Fast Charge / Quick Charge / Super Charge / Turbo Power or whatever. If a voltage higher than 5V is used while charging, the electronics will be destroyed. Never use a cheap charger; this can damage your XC Tracer Maxx II.

We accept no responsibility for damage which occurs when not using the correct voltage for charging!

Automatic shutdown

The XC Tracer Maxx II does not switch off after landing. The vario must always be switched off manually. The idea behind this is that in case of an accident the vario is not switched off automatically, so that FLARM and FANET signals are still transmitted for as long as possible, which can be used by the SAR services to track and find you.

The XC Tracer Maxx II has a low voltage protection circuit and switches off if the battery voltage drops below 3.3V however it is advisable to always turn off the variometer immediately after landing.

Screens

XC Tracer Maxx II can display several predefined screens:

- Simple
- Standard
- Thermal
- Buddy
- Airspace

The predefined screens cannot be customized except in a very limited way, however it is possible to define which screens should be displayed in flight.

Simple

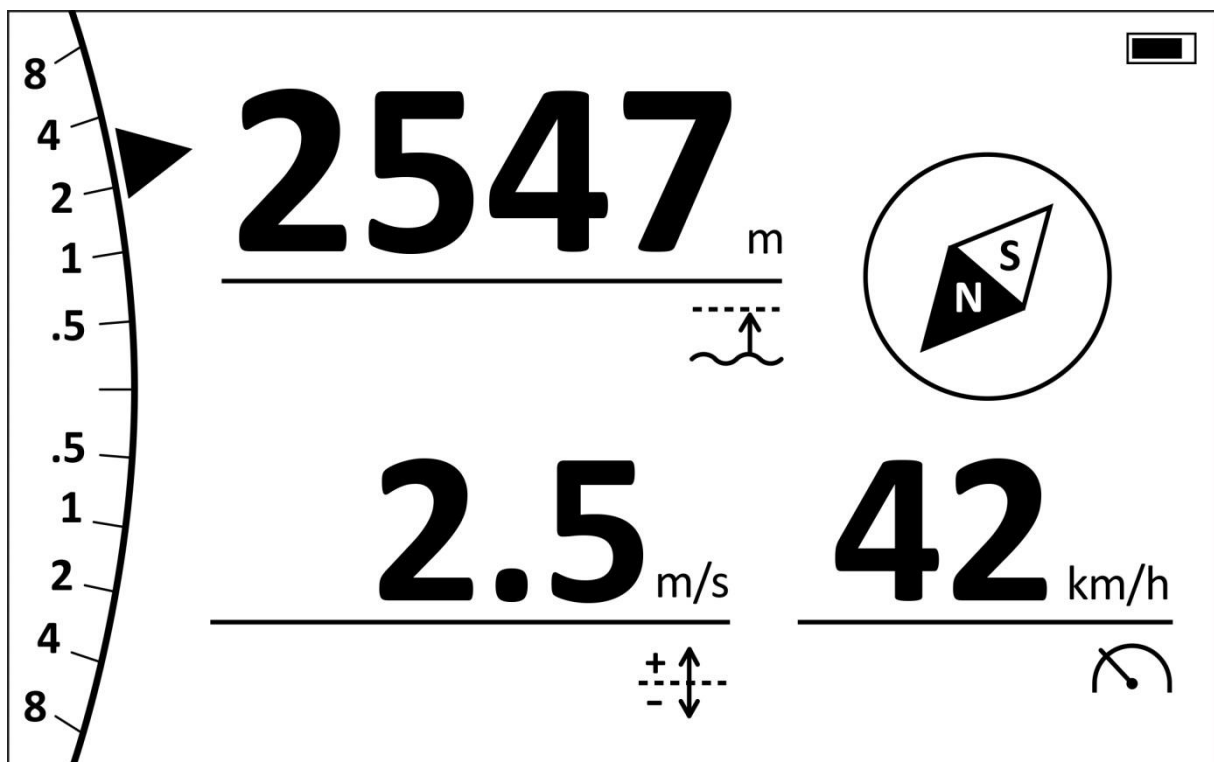

This is the ideal screen if you don't want too much information displayed. The analogue vario indicator shows you the climb/sink rate in weak thermals with a high resolution, but you can also read the climb rate in strong thermals without any problems,

The digital vario shows the average climb rate, you can set the averaging time. The average climb rate is also shown in the analogue vario display as a triangle which is not filled.

Height is height above sea level, or height above ground, or both.

Speed shows the speed over ground.

And the compass always shows you where north is. Please do not use this feature to fly in clouds or in foggy conditions.

Standard

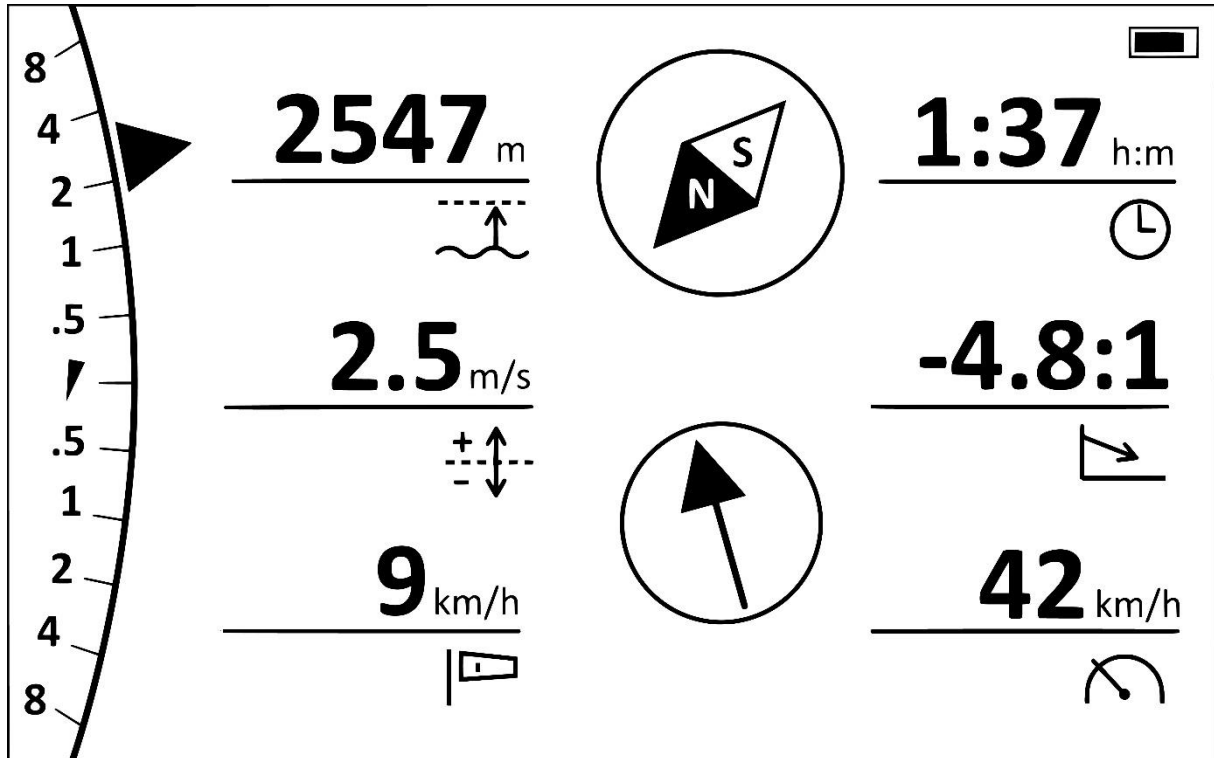

The standard screen will be the ideal screen for many pilots.

The displays are exactly the same as in the simple screen.

In addition to the Simple Screen, the Standard Screen also displays the glide ratio, as well as the current flight duration and/or the current time.

The wind is also displayed. If the wind arrow is pointing upwards it means that the code cannot calculate the wind. But as soon as the wind can be calculated, the wind is displayed, i.e. the arrow shows where the wind is blowing to. Even when soaring on a slope, XC Tracer Maxx II can calculate the wind. The calculation of the wind usually works very well, but there can also be situations where this is not the case.

Thermal

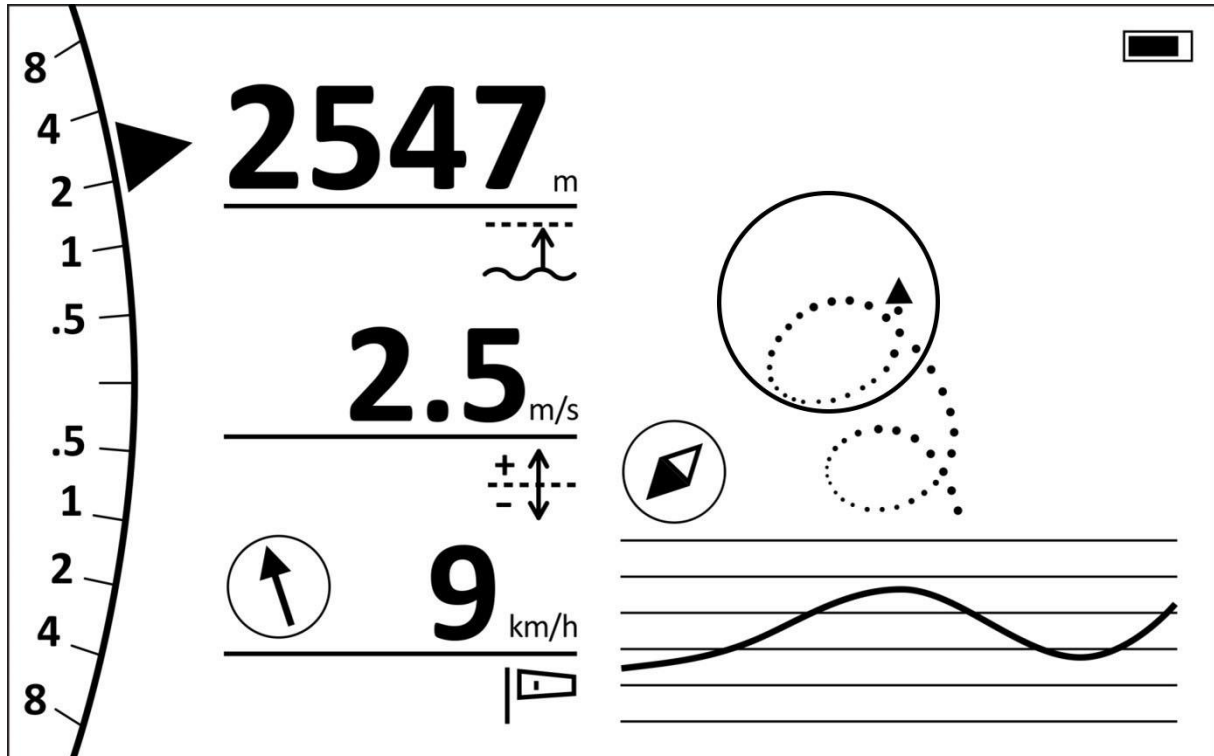

The analog variometer display, altitude above sea level, digital variometer, wind, and compass are identical to the standard screen but arranged differently.

In the settings, you can choose whether to automatically switch from the standard screen to the thermal screen and back. If you set `AutomaticSwitchBack=16s`, the device will automatically switch between the standard and thermal screens after 16 seconds. The variometer recognizes whether you are flying in thermals or not.

The circle indicates the thermal center. You can adjust the diameter of the circle; a good value is 40 meters.

In the bottom right, the altitude line for the last 30 seconds is displayed. This feature can be very helpful to quickly determine whether you have gained or lost altitude. Above the altitude line, the Thermal Assistant shows the last 60 seconds of flight with dots. Filled dots indicate climbing, while unfilled dots indicate sinking. The size of the dots corresponds to the associated variometer value. Large black dots indicate strong lift, while small empty circles indicate weak sinking.

This Thermal Assistant can be very useful if you have fallen out of the thermal and want to find it again. It remains important to continue monitoring the airspace around you and not to focus solely on the variometer. It's best to try out the Thermal Assistant when you are alone in a thermal.

Buddy

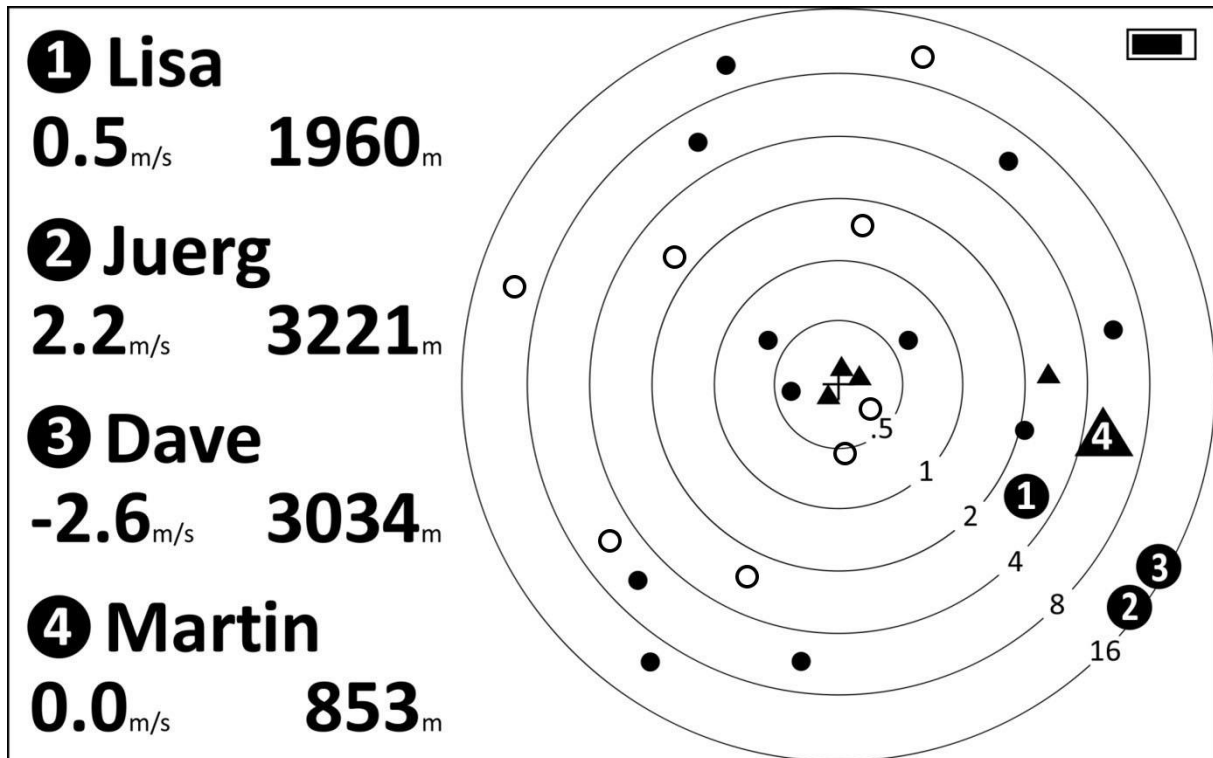

On the Buddy Screen you see the positions of paraglider and hang glider pilots equipped with FLARM/FANET received by the XC Tracer Maxx II in the last 5 minutes. Your position is at the center. The distance to the buddies doubles with each circle.

Triangles indicate buddies who have either not yet taken off or have already landed. Small dots show buddies who are higher than you, while small circles mark buddies who are lower than you.

In the Buddy List (located in the "Buddy" folder on the SD card) you can define the radio ID and corresponding names of up to 50 buddies and then select up to 8 buddies whose locations you want to track – for example, Lisa, Juerg, Dave, and Martin. These selected buddies are displayed as large dots or triangles. The altitude and climb rate of these buddies are shown, keeping you informed about where your friends are.

With a few clicks on the red button, a buddy can be added or selected at the takeoff site. You can find more information on this in the following pages.

If you have defined more than 4 buddies, the information of the first 4 buddies is displayed for 10 seconds. Then, information for buddies 5-8 is shown for another 10 seconds. After that, the display cycles back to buddies 1-4, and so on.

It's important to know that the position, altitude, and status (flying or not) of your buddies are continuously saved in the variometer. This can be useful in case you need to search for a buddy, giving you a starting point for the search. This information can be accessed in the settings under "Buddy - Search / Rescue Buddy."

Airspace

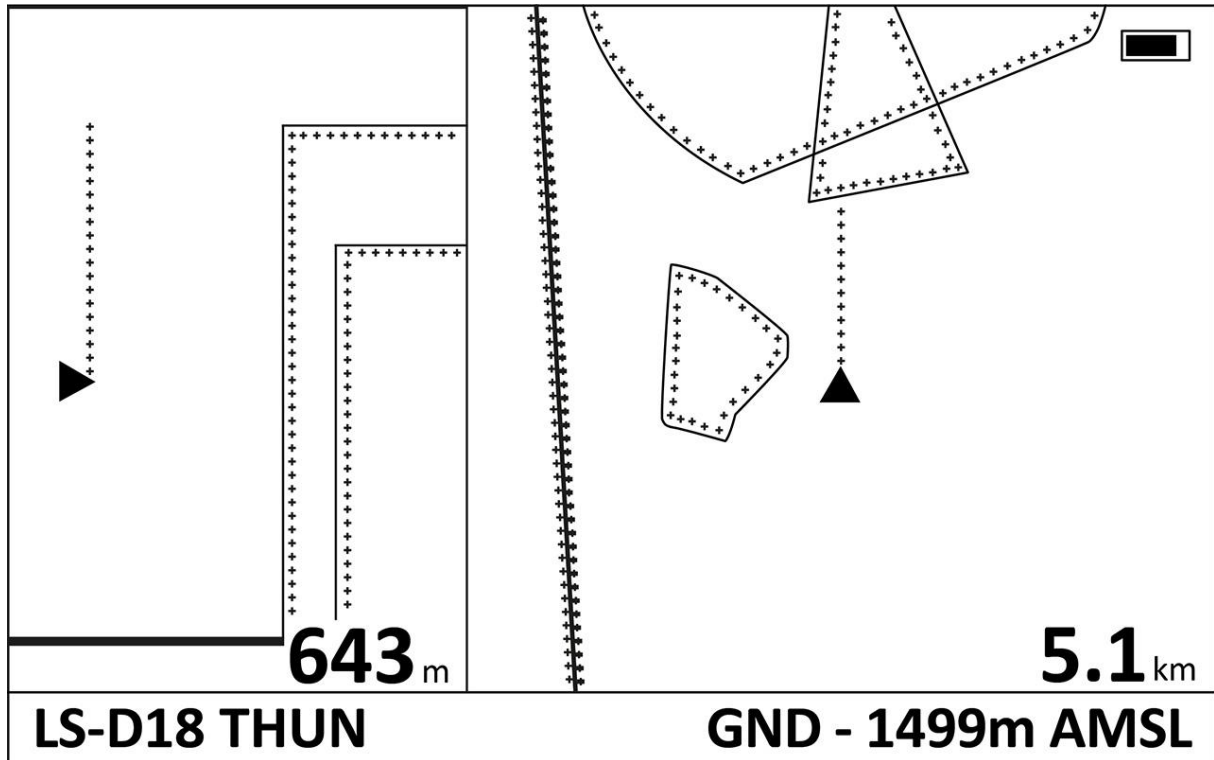

This is what the Airspace screen of the Maxx II looks like when you are approaching an airspace. On the left is the side view, and on the right is the top-down view. The numbers on the left show the vertical distance to the next airspace, and the numbers on the right show the horizontal distance to the next airspace.

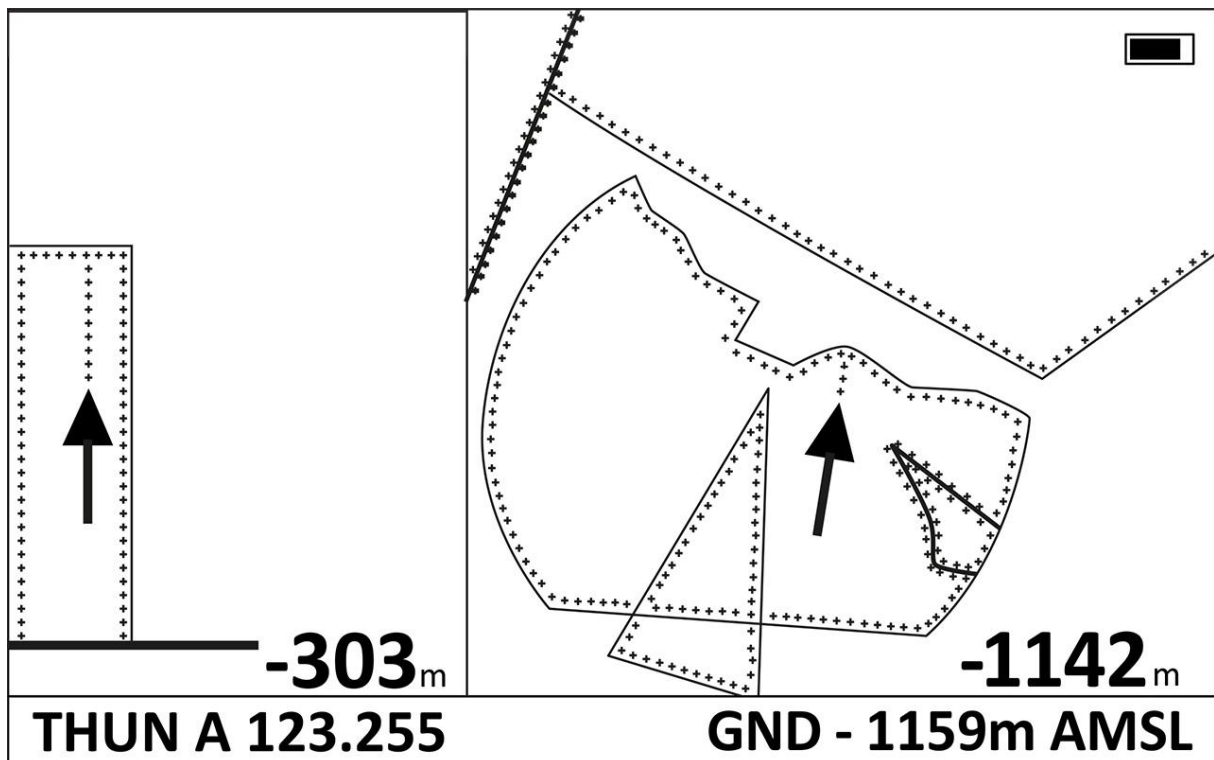

When you are inside an airspace, the two arrows indicate the shortest way out of the airspace. The displayed distance is then the vertical/horizontal distance to the edge of the airspace

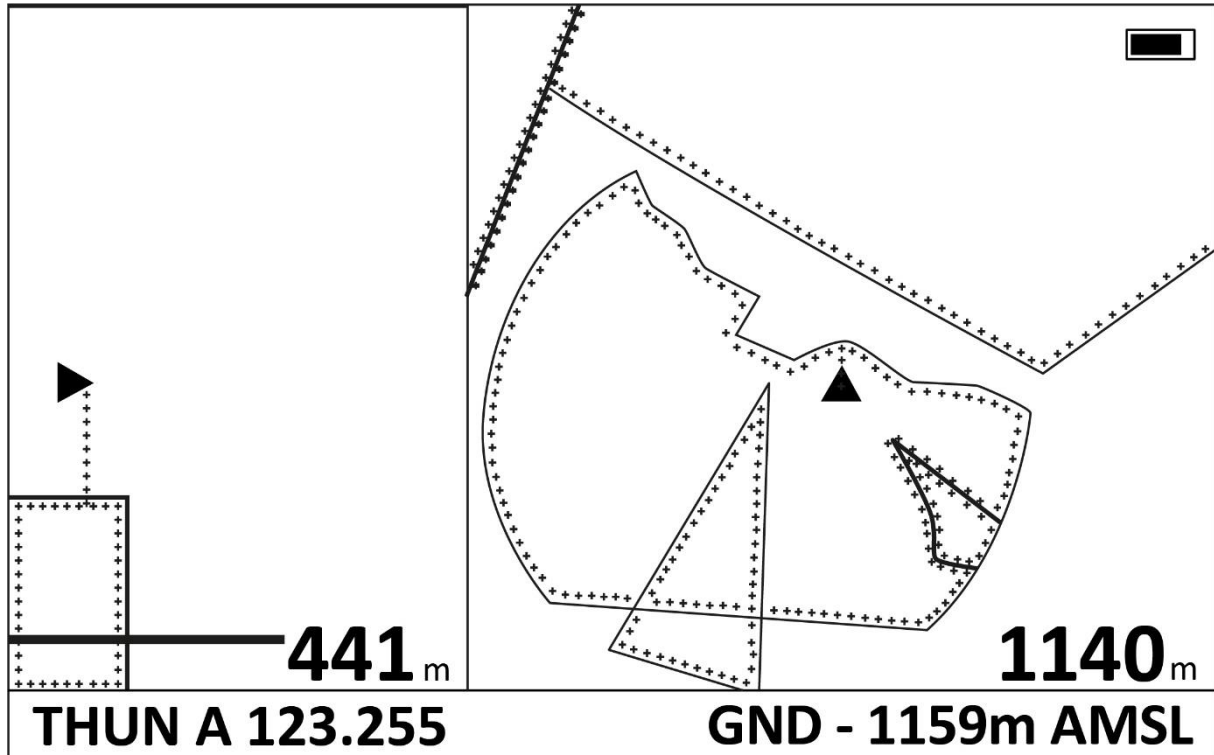

This is what it looks like when you are above an airspace.

Airspace and obstacle data can be downloaded from airspace.xcontest.org in the XC Tracer format:

1. Go to <https://airspace.xcontest.org/>
2. Click on "+Add country" at the bottom left and add, for example, Switzerland.
3. Activate the "Obstacles" and "Airspaces" options at the top left.
4. Click on "Export".
5. Select the "XC Tracer" option.
6. Check the "Hide alerts" box.
7. Click on "Export" again, and the "airspaces.bin" file will be downloaded.
8. Connect your XC Tracer Maxx II to your computer and turn it on.
9. The XC Tracer Maxx II will appear in Finder (Mac) or File Explorer (Windows).
10. Open the XC Tracer in Finder or File Explorer.
11. Move the "airspaces.bin" file to the "Airspace" folder.
12. Eject the XC Tracer and then turn off the variometer.

Adjusting settings directly on the variometer without a computer

If you want to change or view settings: press the red button twice in quick succession and hold it down for a second on the second press. This will take you to the menu. To navigate to the desired setting, press the button once briefly; a long press changes or selects the setting.

The menu includes the following settings:

Flight Book

Here you see information about your recent flights. Please note that you cannot delete flights. This serves only as a statistic in the flight log.

Buddy

With "*Add Buddy Nearby*" you can add an unknown buddy at the takeoff site. To do this, turn on your XC Tracer Maxx II and your friend's variometer, wait until both variometers have GPS reception and now you're ready to start. "Add Buddy Nearby" displays all FLARM/Fanet devices within a 50m radius around you. Navigate with short clicks to the device ID of the buddy and then select it with a long button press. Your buddy's ID is now saved and can no longer be selected. Optionally, you can also change the name of the buddy.

Note: If a buddy is already saved in the address book, you cannot select them this way. Please use "*Add Buddy From Address Book*" for this.

If you want to give a buddy a different name than, for example, "Buddy3," you can do this later on the computer by changing the name of the buddy in the "BuddyList.txt."

Under "*Add Buddy From Address Book*" you can select a buddy from the list saved in the "Buddy" folder under "BuddyList.txt." When you add a buddy with "Add Buddy Nearby," they are automatically saved in the "BuddyList.txt." For example, you can save up to 50 buddies from your club in this list. At the takeoff site, you can then quickly select up to 8 buddies who are also at the site with "*Add Buddy From Address Book*" You can immediately see whether a buddy is already flying or has not yet taken off. However, the condition is that this buddy has their flight instrument with FANET/FLARM turned on.

Under "*Remove Buddy*" a buddy can be removed, meaning they will no longer be displayed on the screen. However, the buddy is not removed from the "BuddyList.txt."

Under "*Search / Rescue Buddy*" you can check where your 8 buddies, which you have selected for display on the screen, were the last time the XC Tracer Maxx II received a FANET/FLARM signal. This can be helpful in search and rescue operations to quickly find a missing pilot.

With "*ShowBuddy*" you can adjust the zoom of the Buddy Screen. Buddies up to 8km, 16km, or 32km away can be displayed.

Screens

Here you can select which screens should be displayed and in what order. Please note: The automatic switching to and from the thermal screen only works if the thermal screen is selected as Screen2.

Screen Options

Here you can make various settings for the screens.

Under *Standard Screen Options*, you can set the following:

Altitude=....

You can choose whether to display altitude above sea level (MSL), altitude above ground (AGL), or just one of these options. Either the GPS altitude and the altitude above ground are displayed, just the GPS altitude, or only the altitude above ground.

LocalTime=.....

Here, you can set the local time. Please note that this requires GPS reception. The switch between winter and summer time does not happen automatically.

Time=....

Here, you can choose whether to display only the flight time, the local time, or both the flight time and local time.

SwitchScreenWithTap=....

You can set how the screen switches. With the "DoubleTap" setting, the screen switches when you make a light double tap with your finger from the left or right on the variometer. With "Single Tap," only one tap is needed, while "No" disables this function.

This feature can be useful if you want to switch screens without having to let go of the brakes to press the red button. With a pod harness, normally a double tap with your hand on the suspension lines is enough to switch the screen. However, note that the variometer cannot distinguish between vibrations from the pilot and turbulent thermals, so there may be false switches depending on the harness and turbulence. Generally, though, DoubleTap works quite well.

As an alternative to "SwitchScreenWithTap", we offer a small remote control that can be attached to the risers - the XC Tracer Remote Control. With this remote, you have full access to the variometer from the riser. You can change settings on the variometer or quickly change the screen without having to release the brakes. However, please note that the variometer cannot be turned off with the remote control.

VarioAverage=....

Here, you can set the integration time for the digital variometer display, from 0 seconds (no integration) to 20 seconds. The best option is probably 20 seconds, as this provides the average climb over a full circle in a thermal.

Under *Thermal Screen Options*, you can set the following:

AutomaticSwitch....

With "AutomaticSwitchScreen=no," the screen will not automatically switch from the standard screen to the thermal screen and back.

With "AutomaticSwitchBack," you can set the time within which the screen will switch back to the standard screen once you resume straight flight. A value between 14 and 16 seconds is

recommended, as this prevents the screen from switching back immediately if you are searching in the thermal and flying straight for a while.

WindThermalScreen=...

If you select "Wind & Speed," both the wind speed and the ground speed will be displayed. However, you can also choose to display only the wind.

CircleThermalFinder=...

With "CircleThermalFinder=...", you can select the size of the circle to be displayed in the thermal finder. The diameter can be set between 25 and 70 meters. A recommended value is 40 meters. Alternatively, you can turn the circle off.

In the ***Airspace Screen Options***, you can make various settings for the airspace screen.

"*TopViewResolution*" allows you to define the size of the map section.

"*SideViewResolution*" lets you set the scaling of the side view.

"*AlarmDistanceHorizontal*" allows you to define a horizontal alarm distance.

"*AlarmDistanceVertical*" enables you to set a vertical alarm distance.

"*AwareDistanceHorizontal*" lets you define a horizontal pre-warning distance.

"*AwareDistanceVertical*" allows you to set a vertical pre-warning distance.

"*AwareShowTime*" can be set to determine how long the airspace screen should be displayed when a pre-warning occurs.

When you approach an airspace and cross the aware distance, an acoustic signal sounds, and the airspace screen is displayed for the duration defined in "AwareShowTime." This duration should be set long enough to assess the situation. After "AwareShowTime" expires, the display automatically switches back to the previous screen.

In the event of an airspace alarm, the display automatically switches to the airspace screen. To return to the previous screen, you must press the red button, use the remote control, or, if active, switch back with Single/Double Tap.

Under ***Tone & Alarm***, you can set how often you should be warned about the same airspace.

In the ***Buddy Screen Options***, you can set the maximum distance over which buddies should be displayed.

Under Units, you can configure the units to be used for speed, altitude, variometer, wind, and distance.

Tone & Alarm

Here you can make various settings regarding sound and alarm.

BeepOnButtonClick=...

Here you can set whether the variometer emits a beep when being operated or not.

BeepOnlyWhenFlying=...

With "BeepOnlyWhenFlying=...", you can set the variometer to beep only when you are flying. This is the standard setting. Otherwise, the variometer will beep at every movement on the launch site.

With "yes", the variometer will start beeping only when you are flying, with the volume level that you can set further down.

SetVolume=...

With "SetVolume=...", you can set the volume at which the variometer beeps during flight.

At 0, the variometer remains silent.

At 1, it beeps quietly, suitable for sensitive ears.

The volume level 2 or 3 is a good choice for many pilots.

If you want maximum loudness, set it to 4.

DampingFactor=...

With "DampingFactor=...", you can adjust the damping. For no or only a slight time delay: Use 0 or 0.5. For maximum damping: Choose a value of 5.

TEK=.....

TEK stands for "Total Energy Compensation". A TEK variometer compensates for the conversion of speed into altitude to avoid unnecessary beeping. Especially when flying with a high-performance paraglider, if after full acceleration and subsequent release of the speed bar, the glider temporarily converts speed into altitude, the variometer will show a temporary climb. This is where the TEK variometer's compensation function comes into play.

However, the benefit of a TEK variometer is limited in thermal flying. If the glider accelerates without actually climbing, the TEK variometer might mistakenly show a climb, which could confuse the pilot as they do not physically perceive any climbing.

To account for this, we offer setting options from TEK=1000ms to TEK=3000ms. When active in straight flight, TEK can contribute to optimizing flight performance and help use updrafts more effectively. When turning into a thermal and switching to the thermal screen, there is a seamless transition from the TEK variometer to the normal variometer within the set time. A setting of 1000ms means that the TEK variometer will seamlessly transition to the normal variometer within this time. This transition also occurs when leaving the thermal and returning to straight flight, switching from the normal variometer back to the TEK variometer.

For many pilots, the setting TEK=no might be the preferred choice to receive consistent feedback throughout the flight.

ObstacleWarnings=.....

The "ObstacleWarnings" setting allows the pilot to determine how often they want to be warned about the same obstacle during a flight. This is particularly useful to avoid unnecessary warnings, especially if there are known obstacles near the launch site or in other areas that the pilot regularly flies over.

For example, if "ObstacleWarnings=2x" is set, the pilot will be warned twice about the same obstacle, and no further warnings for that obstacle will be given during the same flight.

Approximately 10 seconds before a calculated collision with an obstacle, an alarm sounds, resembling the tone of a US police siren. The closer you get to the obstacle, the more urgent the alarm tone becomes. Once you move away from the obstacle, the alarm stops. It's important to note that obstacles are not displayed on the screen but the alarm serves as an auditory warning.

It's crucial to recognise that the effectiveness of this feature greatly depends on the quality and currency of the available obstacle data. Therefore, it's essential to keep the device's obstacle database up to date to ensure reliable warnings of potential collisions. However, pilots should always remain vigilant and continuously look out for obstacles, especially cables that might not be included in the database.

While the variometer relies on the available obstacle data to issue warnings, it's possible that not all obstacles are detected, especially in remote or less frequented flying areas. Thus, it's advisable to consider the obstacle database as an additional tool, not the sole basis for detecting obstacles during flight.

We use the obstacle data from XContest. The obstacle data is included in the airspace data.

AirspaceWarnings=.....

The same principle applies to airspace warnings as to obstacle warnings. You can specify how often you want to be warned about the same airspace. This can be particularly useful when soaring near an airspace. After the second warning, the pilot should already be aware of how far they can fly without violating the airspace. In this case, it is no longer necessary for the alarm to sound again.

Logger & Tracking

LogOnlyWhenFlying=....

If you are doing hike & fly and want to record the track on the ground as well, you should set LogOnlyWhenFlying=no. Otherwise, LogOnlyWhenFlying=yes is the correct setting. Then, the recording of the flight starts as soon as you have taken off, and after landing, the recording in the log file (IGC and KML) ends.

LiveTracking=.....

With LiveTracking=yes, you are visible on OGN / Glidertracker / Burnair. This is the normal setting, as it can be helpful in the event of an accident if people know where you are. With LiveTracking=no, you are not visible on OGN / Glidertracker / Burnair.

Fanet=...

With Fanet=yes, Fanet is turned on, and your Maxx II sends and receives Fanet tracking packets. These are used to display the position of your buddies on the Buddy screen.

Flarm=...

With the setting "Flarm=yes," Flarm is activated, so your Maxx II sends and receives Flarm packets. These packets are used to display the position of your buddies on the Buddy screen. Additionally, Flarm packets are used to warn aircraft of a potential collision with you.

Please check if your Flarm firmware is still up to date. On our homepage, you can find the corresponding radio firmware at <https://www.xtracer.com/downloadsxtracermaxxii>. Firmware updates for XC Tracer are free of charge and do not incur additional costs.

GliderType=....

Here you can set whether your Maxx II is displayed as a paraglider or a hang glider on OGN / Glidertracker. Important: Burnair does not receive packets from hang gliders!

Device Info

Here you can find various information about the variometer, such as firmware version, RadioID, RadioFirmwareVersion, etc.

Exit

From here, you return to the screen you use for flying.

XC Tracer Maxx II Configuration File

A few settings cannot be made directly on the vario. To change them, you have to connect XC Tracer Maxx II with a USB-C cable to a computer, and only then switch on the vario by briefly pressing the red button. Now XC Tracer Maxx II is active in USB mode. The SD card appears in the Windows Explorer or in the Finder of the Mac. The operating instructions are stored on the SD card as a PDF and the configuration file with the name XC_Tracer_Maxx II.txt. In this file the variometer can be adapted to the personal needs. The individual setting options are described below:

XC Tracer Maxx II Configuration File

serialNumber= 688D2E4C8100

Serial number of XC Tracer Maxx II, is used for the IGC logger.

RadioName=Koni23

Radio Name that is sent over FANET

RadioID=2000CA

Radio ID of FANET and FLARM

RadioFirmwareVersion=7.07-0.9.54

Version of radio firmware

RadioExpireDate=20241101

Expiry date of the radio firmware

firmwareVersion=XC_Tracer_Maxx II_R05

Indicates the device's firmware version.

reset=no

Setting *reset=yes* resets XC Tracer Maxx II to the factory default settings. Reset=no is the default setting. After a reset reset=no will automatically be set in the config file.

supported protocols are None, XCTRACER, LK8EX1, LXWPO or LXWPW.

Select the BLE protocol her. NB. Only one protocol can be selected at once. Please check at www.xtracer.com which protocol to choose for your app. LXWPW is like LXWPO, but with the information of the calculated wind.

stringToSend=LXWPO

In this case the LXWPO protocol will be used.

name of BLE service

bleName=XCT

A name for the BLE service can be assigned here, up to 14 numbers and letters are possible. Please do not use a hyphen, some Android Apps have problems with it.

logger configuration

pilotName=Koni Schafroth

Enter your name here. Please don't use accidentally use any tabs as they will invalidate the IGC file. Spaces are fine.

passengerName=

You can enter the name of a tandem passenger here if you like.

gliderType=Gin Explorer

Enter your glider make and model here.

gliderId=14049

Enter the immatriculation number (if you have one) of your glider here.

create your own vario tone settings below

ClimbToneOnThreshold=0.2

With this setting the vario will begin to beep when the climb rate is higher than 0.2m/s. When you want to use a thermal sniffer then you can set *ClimbToneOnThreshold=-0.5* for example. In this case the vario will begin to beep when the sink rate is less than -0.5m/s. In this way you can adjust the beeping tone so that you know when you're flying in lifting air, despite the fact that you're actually sinking gently. This can be helpful to find and core thermals in weak conditions.

ClimbToneOffThreshold=0.1

With this setting the vario will stop beeping when the climb rate is below 0.1m/s. You can also use negative values here, for example -0.51m/s when you use a thermal sniffer.

SinkToneOnThreshold=-3.0

The sink tone will be activated when the sink rate is below -3m/s.

SinkToneOffThreshold=-3.0

The sink tone will be deactivated when the sink rate is less than -3m/s.

tone=-10.00,200,100,100

tone=-3.00,280,100,100

tone=-0.51,300,500,100

tone=-0.50,200,800,5

tone=0.09,400,600,10

tone=0.10,400,600,50

tone=1.16,550,552,52

tone=2.67,763,483,55

tone=4.24,985,412,58

tone=6.00,1234,332,62

tone=8.00,1517,241,66

tone=10.00,1800,150,70

You must define exactly 12 tones. Additional tones will be deleted from the configuration file, and missing tones will be complemented with values stored in the Eeprom. The tones must be defined ascending from tone 1 of -10m/s to tone 10m/s of tone 12.

Important: Please avoid using exactly the same climb rate on adjacent tones as it will create issues.

tone=1.16,579,527,50 means that with a climb rate of 1.16m/s the vario will beep with a frequency of 579Hz, that the complete tone interval will last 527ms, and that the tone will be audible for 50% of the tone interval. This is a typical tone that is used when indicating climbing.

tone=-3.00,280,100,100 means that with a sink rate of -3.0m/s a tone of 280Hz will be emitted. As soon as the sink rate changes the tone frequency also changes, depending on the configuration. This creates a nice sink tone (not that a sink tone is ever nice!)

You can create your own tone settings using the tone simulator on xctracer.com and then copy and paste them to the configuration file, or you can simply copy and paste other people's tone settings into the configuration file.

Important: Always close the configuration file before you unmount / eject XC Tracer Maxx III!!!

Important: Always save and close the config file before switching off the XC Tracer Maxx III!

Important: Before switching off the vario, please always eject the SD card from the computer. This also applies to firmware updates!

Important: After changing the config file, the XC Tracer Maxx II must be switched on in flight mode so that the settings of the config file are applied and saved in the eeprom.

Radio Firmware / Update

The radio firmware must be updated annually. In the settings you can check which firmware version is installed and until when this firmware is valid.

After this expiration date, the radio firmware will no longer work with FANET / FLARM! An update must be done before this date!

Please check xtracer.com if a new radio firmware (*.fw file) is available. These firmware updates are free of charge, the installation is easy by drag & drop. For instructions on how to perform a firmware update, see below.

Collision warning

Your XC Tracer Maxx II transmits your position and estimated trajectory for the next 20 seconds every second. All other FLARM devices in the vicinity can use this information to estimate a possible collision risk. If another FLARM device determines that a collision is possible, it warns the pilot of the other aircraft.

XC Tracer Maxx II itself does not warn of possible collisions with other aircraft!

XC Tracer Maxx II can receive signals from FANET devices of paragliders and hang gliders and transmit the data to a cell phone, tablet or e-reader. Depending on which app you use, you'll always know where your buddies are. During flight tests under optimal conditions, signals were received from FANET devices up to 140 km away.

Obstacle Warning

Maxx II uses an obstacle database from XContest integrated in the airspaces.bin on the SD card to calculate the distance to nearby obstacles while you are flying. When the calculated time to impact is less than 12 seconds, an alarm sound similar to an American police siren will be triggered. The closer you get to the obstacle, the higher the pitch of the alarm. If the alarm sounds, it is recommended to make a 90-degree turn to the left or right from your flight path. The alarm will stop once the risk of collision is no longer present. No alarm will be triggered if you fly more than 100 meters above an obstacle.

XC Tracer Maxx II Firmware Update

Connect XC Tracer Maxx II to a computer using a USB-C cable and once connected, switch the device on by briefly pressing the red button until you hear a beep-beep-beep. XC Tracer Maxx II is now running in USB-MSD (Mass Storage Device) mode. XC Tracer Maxx II's internal Micro SD Card will appear as an external drive in Windows Explorer or the Mac Finder. Download the newest flight firmware for XC Tracer Maxx II and the newest FLARM firmware from xctracer.com and copy the new firmware using drag and drop to the SD card. Now press the red button briefly and the new firmware will start to be installed.

When the XC Tracer Maxx II firmware [* .iap file] is updated, after a short time a few ascending beeps sound, the firmware file is deleted from the SD card and the vario switches off. The new firmware is now installed.

An update of the FLARM firmware takes much longer, after pressing the red button it will last 1-5 minutes until a few ascending beeps will sound, the FLARM firmware file or obstacle database file will be deleted from the SD card and the vario will turn off. The new version is now installed.

Important: The information about the firmware version will only be updated once the device has been started up in normal flight mode. Only one update at a time. If you want to update 2 files you have to repeat the process.

It's impossible to install incorrect firmware on the XC Tracer Maxx II – all that happens is that the incompatible firmware will get deleted from the SD card.

Troubleshooting

In the rare event that XC Tracer Maxx II doesn't respond when you push the red button, you can perform a hard-reset by pressing and holding the red button for approximately 1 minute. The battery will then get disconnected from the electronics. After that you can restart XC Tracer Maxx II in flight mode, and the device will be functional again.

Handling

A variometer is a sensitive device, the electronics, the sensors and the LCD display can be damaged by strong impacts or shocks. Handle your instrument with care!! Please only expose the vario to the sun during the flight, otherwise the instrument can become very hot. This can cause the battery to overheat and destroy the battery and the vario! The LCD can also be damaged by excessive heat or a lot of UV light. The vario is not waterproof.

Warranty

XC Tracer grants a 24 month warranty for material and workmanship. Unsuitable or improper use (for example strong impact, water landing, opened enclosure, software modification, ripped off USB connector, broken lcd etc.) and normal wear and tear (scratches in the enclosure, degradation of the battery) are excluded from the guarantee.

Technical Specification

- High-resolution B&W LCD, 536x336 pixels, perfectly readable
- Hardened and glare-free glass for LCD protection
- Five different screens selectable, from simple screen to air spaces
- Simplest operation
- Legendary sensitive vario technology, with no time lag
- FLARM with transmission data
- Open source obstacle database
- FANET display of position and height of Buddies
- Internal broad band antenna, works worldwide
- Data transmission via BLE to mobile phone/tablet/E-reader
- IGC and KML Logger, approved by the FAI for competitions
- Many compatible apps for Android/iOS
- Freely configurable sound settings with our tone simulator
- Accelerometer/Compass/Gyro/Baro/GPS/BLE/FLARM
- Running time with full battery at least 60h
- Firmware update via drag & drop
- Running time with full battery up to 70h
- Size: 92x68x18 mm
- Weight 120g
- CE and FCC Certification
- Swiss Made

FCC Statement:

Changes or modifications not expressly approved by the party responsible for compliance could void the user's authority to operate the equipment.

This device complies with part 15 of the FCC Rules. Operation is subject to the following two conditions:

(1) This device may not cause harmful interference, and

(2) This device must accept any interference received, including interference that may cause undesired operation.

FCC ID: 2AVOQ02 / Contains FCC ID: XPYANNAB1